

1406-0015		
	mm	inch
L1	1950	76 3/4
L2	1879	74
L3	1445	56 9/10
L4	1100	43 1/3
L5	846	33.31
L6	740	29 1/8
L7	525	20 7/10
L8	675	26 6/10
L9	375	14 3/4
L10	1490	58.66
W1	950	37 3/8
W2	887	34 9/10
W3	629	24 3/4
W4	340	13 2/5
W5	725	28 4/7
W6	615	24 1/5
W7	750	29 1/2
H1	575	22 5/8
H2	450	17 3/4
H3	77	3

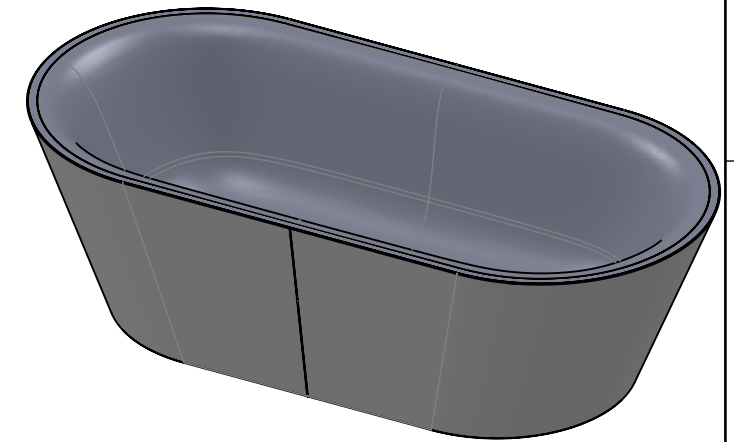

Glazed titanium steel

All Products are manufactured in the same place and go through the same processes. Surface materials and steels are identical.

Änderungen	a	10.03.2016	LB	ZeichnuNr	-	-	Erstellt	24.03.2016	LB	Massstab <b>1:20</b>	
	b	20.05.2016	LB	Masse	-	-	Geprüft		-		
	c	25.08.2016	LB	Überlauf	-	-	Freigegeben		-		
	d	11.11.2016	LB	Überl. 52	-	-	Auftrags-Nr.				
Ohne sep. Stückliste		<input type="checkbox"/>	SGVSB Nr.				Status				
Sep. Stückliste gleicher Nr.		<input type="checkbox"/>	ST Nr.				Ursprung			Format <b>A3</b>	Blatt / Anz. <b>4 / 6</b>
Sep. Stückliste anderer Nr.		<input type="checkbox"/>	Artikel-Nr.		1406-0015		Ersatz für			Zeichnungs-Nr. <b>01.002.1284</b>	Index <b>d</b>
<b>Schmidlin</b> <sup>TM</sup>		<b>Schmidlin SELLA SHAPE</b>		Freestanding bathtub 76 3/4"x37 3/8"x22 5/8"						Plotdatum: 29.03.2018	
www.schmidlin.ch											