

1 2 3 4 5 6 7 8

A B C D E F

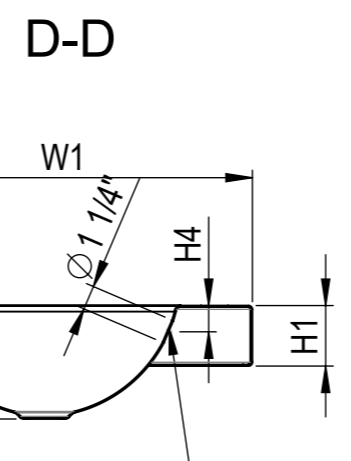

Optional with overflow hole 1209-0006

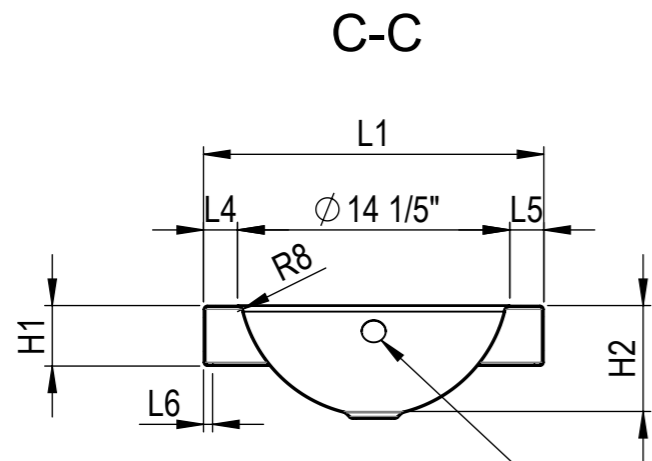
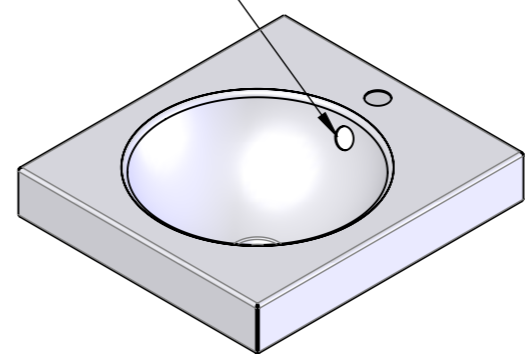
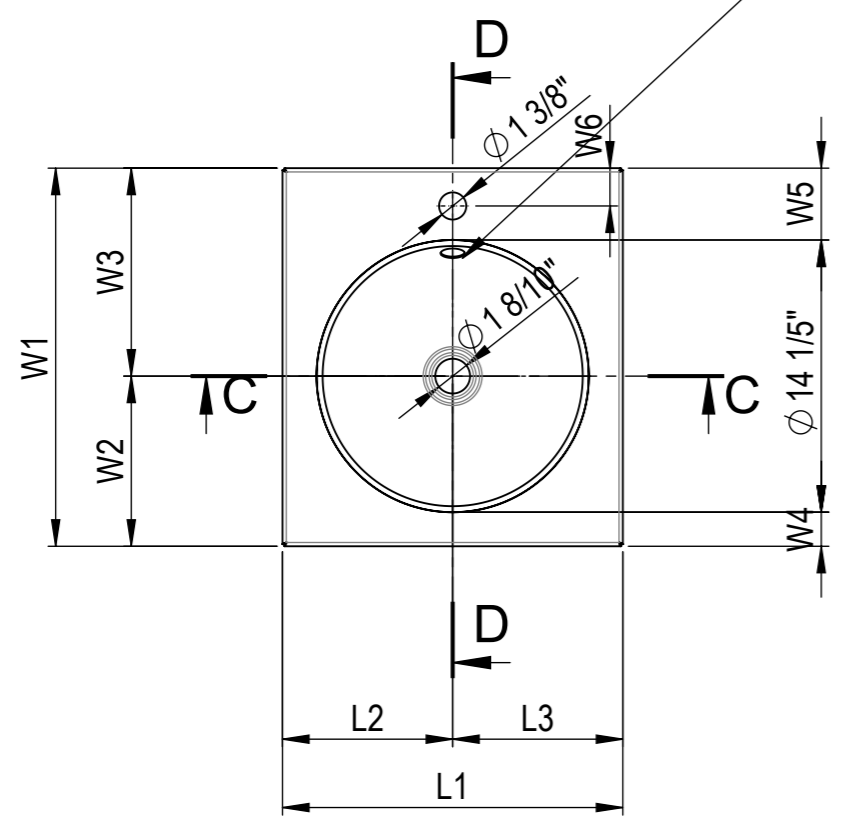

	1209-0004 1209-0006*	
	mm	inch
L1	450	17 3/4
L2	225	8 9/10
L3	225	8 9/10
L4	45	1 3/4
L5	45	1 3/4
L6	12	1/2
W1	500	19 5/8
W2	225	8 9/10
W3	275	10 8/10
W4	45	1 3/4
W5	95	3 3/4
W6	50	2
H1	80	3 1/8
H2	140	5 1/2
H3	150	5 9/10
H4	35	1 2/5

\*Washbasin with overflow hole

Glazed titanium steel

All Products are manufactured in the same place and go through the same processes. Surface materials and steels are identical.

Änderungen	a	07.03.2013	LB Innenkörper	Änderungen	e	24.03.2017	LB overflow	Erstellt	11.01.2013	LB	Massstab <b>1:10</b>
	b	26.04.2013	LB Bemassung		-	-	-	Geprüft	-	-	
	c	05.12.2016	LB ArtikelNr		-	-	-	Freigegeben	-	-	
	d	05.12.2016	LB ZeichnuNr		-	-	-	Auftrags-Nr.	-	-	
Ohne sep. Stückliste		<input type="checkbox"/>	SGVSB Nr.	-		Status					
Sep. Stückliste gleicher Nr.		<input type="checkbox"/>	ST Nr.	-		Ursprung		Format		Blatt / Anz.	
Sep. Stückliste anderer Nr.		<input type="checkbox"/>	Artikel-Nr.	1209-0004 1209-0006		Ersatz für		A3		2 / 2	
<b>Schmidlin</b> <sup>TM</sup>			<b>Schmidlin ORBIS counter-top</b>			Zeichnungs-Nr.		Index			
www.schmidlin.ch			17 3/4"x19 5/8"x3 1/8" with faucet hole			01.002.0391		e			