

Optional with overflow hole 1066-0005

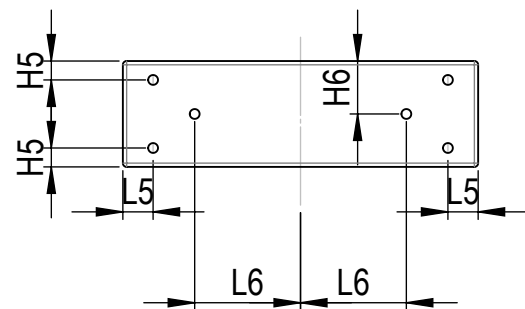
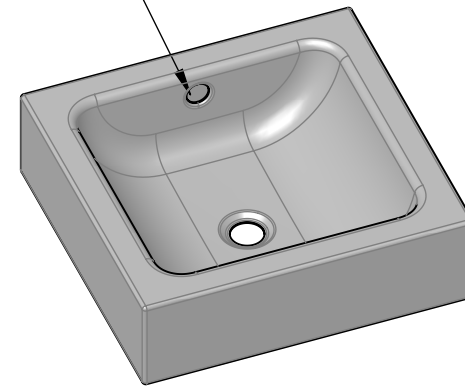
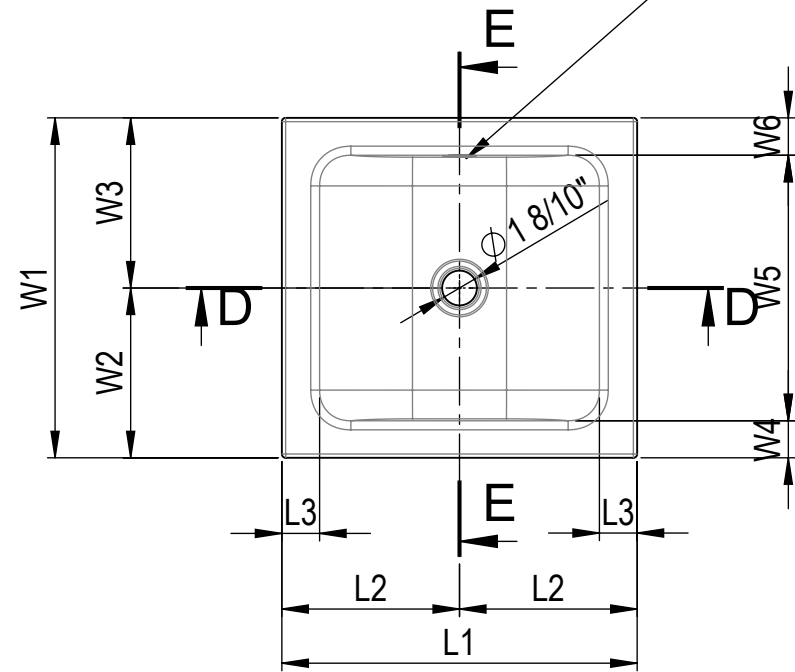

	1066-0003 1066-0005*	
	mm	inch
L1	470	18 1/2
L2	235	9 1/4
L3	50	2
L4	10	4/10
L5	40	1 3/5
L6	140	5 1/2
W1	450	17 3/4
W2	225	8 9/10
W3	225	8 9/10
W4	49	1 9/10
W5	351	13 8/10
W6	49	1 9/10
H1	140	5 1/2
H2	130	5 1/10
H3	140	5 1/2
H4	40	1 3/5
H5	25	1
H6	70	2 3/4

Glazed titanium steel

All Products are manufactured in the same place and go through the same processes. Surface materials and steels are identical.

*Washbasin with overflow hole

Änderungen	a	15.12.2014	LB	Rand V+H	-	-	Erstellt	08.11.2012	LB	Massstab 1:10
	b	14.04.2016	LB	ArtikelNr	-	-	Geprüft		-	
	c	14.04.2016	LB	ZeichnuNr	-	-	Freigegeben		-	
	d	24.03.2017	LB	overflow	-	-	Auftrags-Nr.			
Ohne sep. Stückliste		<input type="checkbox"/>	SGVSB Nr.				Status			
Sep. Stückliste gleicher Nr.		<input type="checkbox"/>	ST Nr.				Ursprung		Format A3	
Sep. Stückliste anderer Nr.		<input type="checkbox"/>	Artikel-Nr.		1066-0003 1066-0005		Ersatz für		Blatt / Anz. 2 / 2	
Schmidlin TM		Schmidlin CONTURA wall-mounted		Zeichnungs-Nr.		Index				
www.schmidlin.ch		18 1/2"x17 3/4"x5 1/2"		01.002.0339		d				