

We reserves all rights in this document and its subject matter. The recipient hereby acknowledges these rights and assures the use of this document only for the purpose it was delivered. © Wilhelm Schmidlin AG

Dieses Dokument ist unser geistiges Eigentum. Es darf ohne unsere ausdrückliche Genehmigung weder kopiert, vervielfältigt oder verwendet, noch an Dritte weitergegeben werden. Zuwiderhandlung ist strafbar und wird strafrechtlich verfolgt. Copyright reserved! © Wilhelm Schmidlin AG

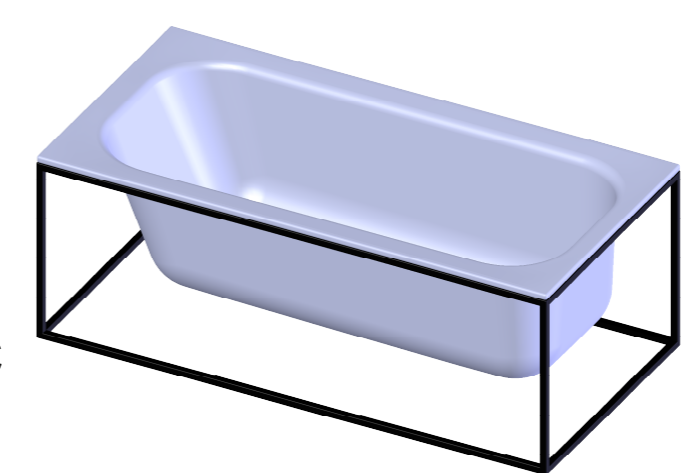
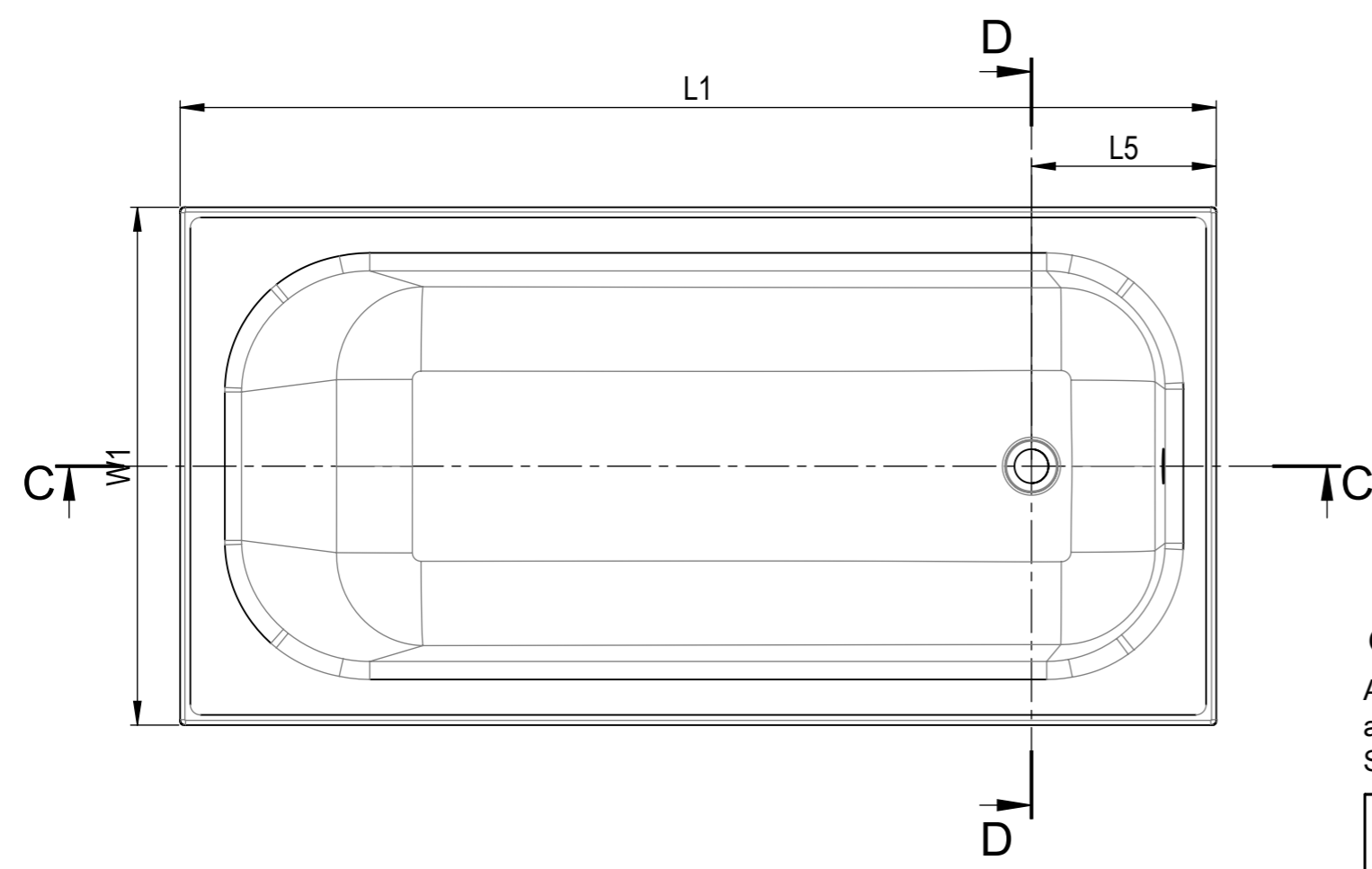
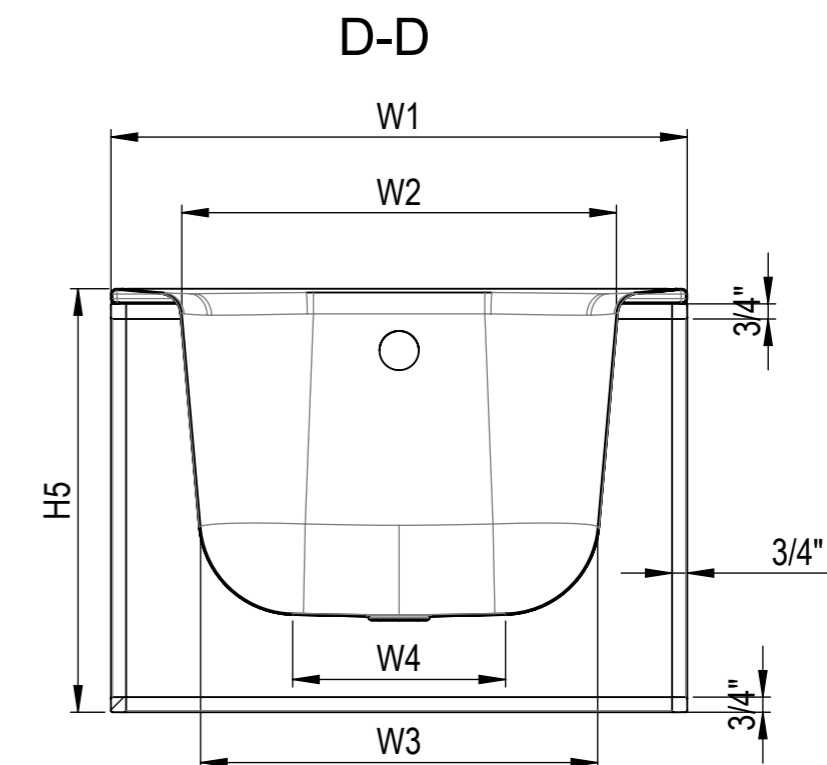
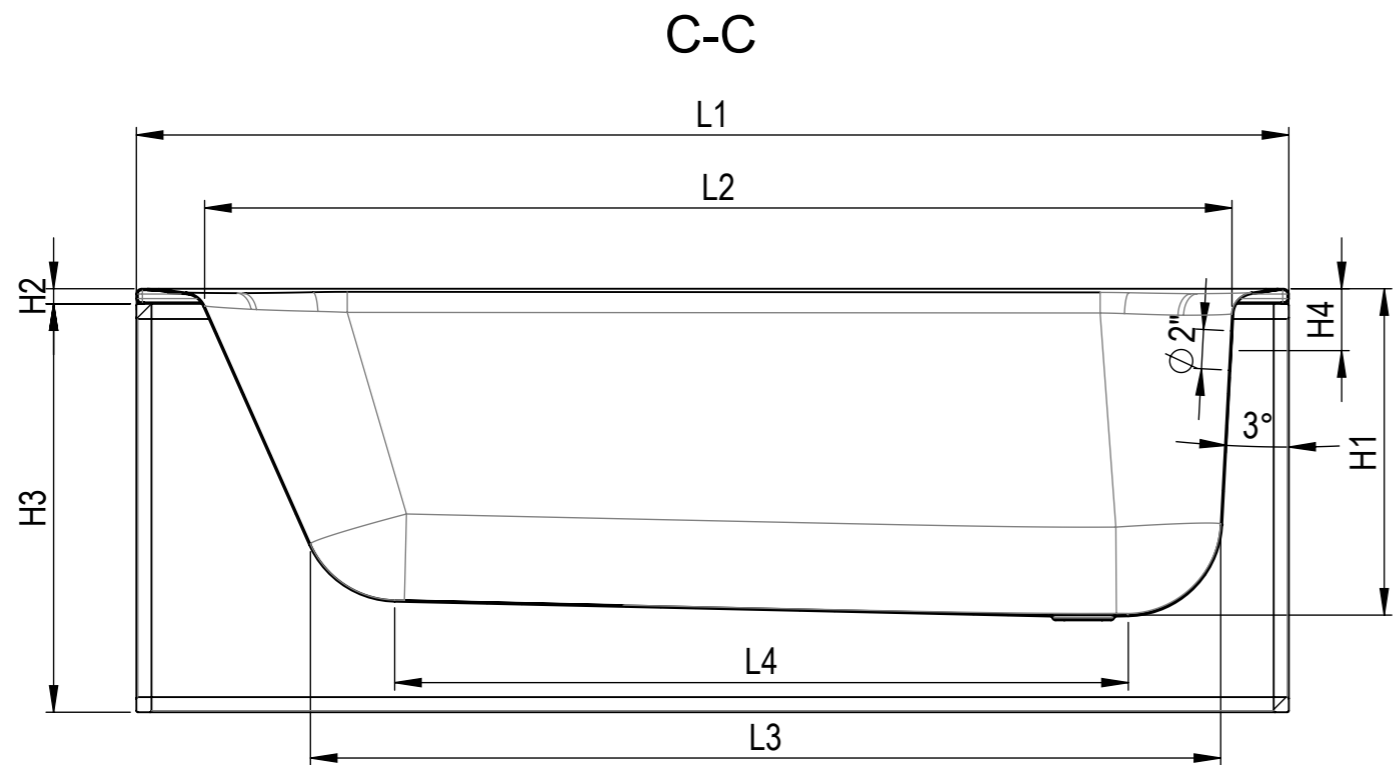

	mm	inch
L1	1524	60
L2	1359	53 1/2
L3	1204	47 2/5
L4	970	38 1/5
L5	270	10 3/5
W1	762	30
W2	575	22 5/8
W3	525	20 7/10
W4	282	11 1/10
H1	440	17 1/3
H2	20	3/4
H3	540	21 1/4
H4	80	3 1/7
H5	560	22

Glazed titanium steel  
 All Products are manufactured in the same place and go through the same processes.  
 Surface materials and steels are identical.

Anderungen		Anderungen		Erstellt	16.04.2018	LB	Masstab
-	-	-	-	Geprüft		-	1:10
-	-	-	-	Freigegeben		-	
-	-	-	-	Auftrags-Nr.			
Ohne sep. Stückliste <input type="checkbox"/>		SGVSB Nr. -		Status			
Sep. Stückliste gleicher Nr. <input type="checkbox"/>		ST Nr. -		Ursprung		Format	Blatt / Anz.
Sep. Stückliste anderer Nr. <input type="checkbox"/>		Artikel-Nr. -		Ersatz für		A3	2 / 2
<b>Schmidlin</b> <sup>TM</sup>		<b>Schmidlin NORM FRAME</b>				Zeichnungs-Nr.	
www.schmidlin.ch		60"x30"				01.004.1987	
						Index	